

The Premium System for Professional
Tool Presetting and Measuring

ZOLLER
expect great measures

venturion



Premium is a Promise – and an Attitude

Choosing »venturion« from ZOLLER means having all the benefits of a premium presetting and measuring machine on your side every day.

Measure complex tools with the highest precision, down to the µm. Benefit from the flexibility of a modular system that adapts ideally to your processes. Networked production, digital tool management, data exchange with external systems – enter the production world of the future. Because we understand the future is a long-term project, a »venturion« is built so robustly that it will accompany you for a very long time.

With »venturion«, you're prepared for the highest demands when measuring and presetting tools.

»venturion«

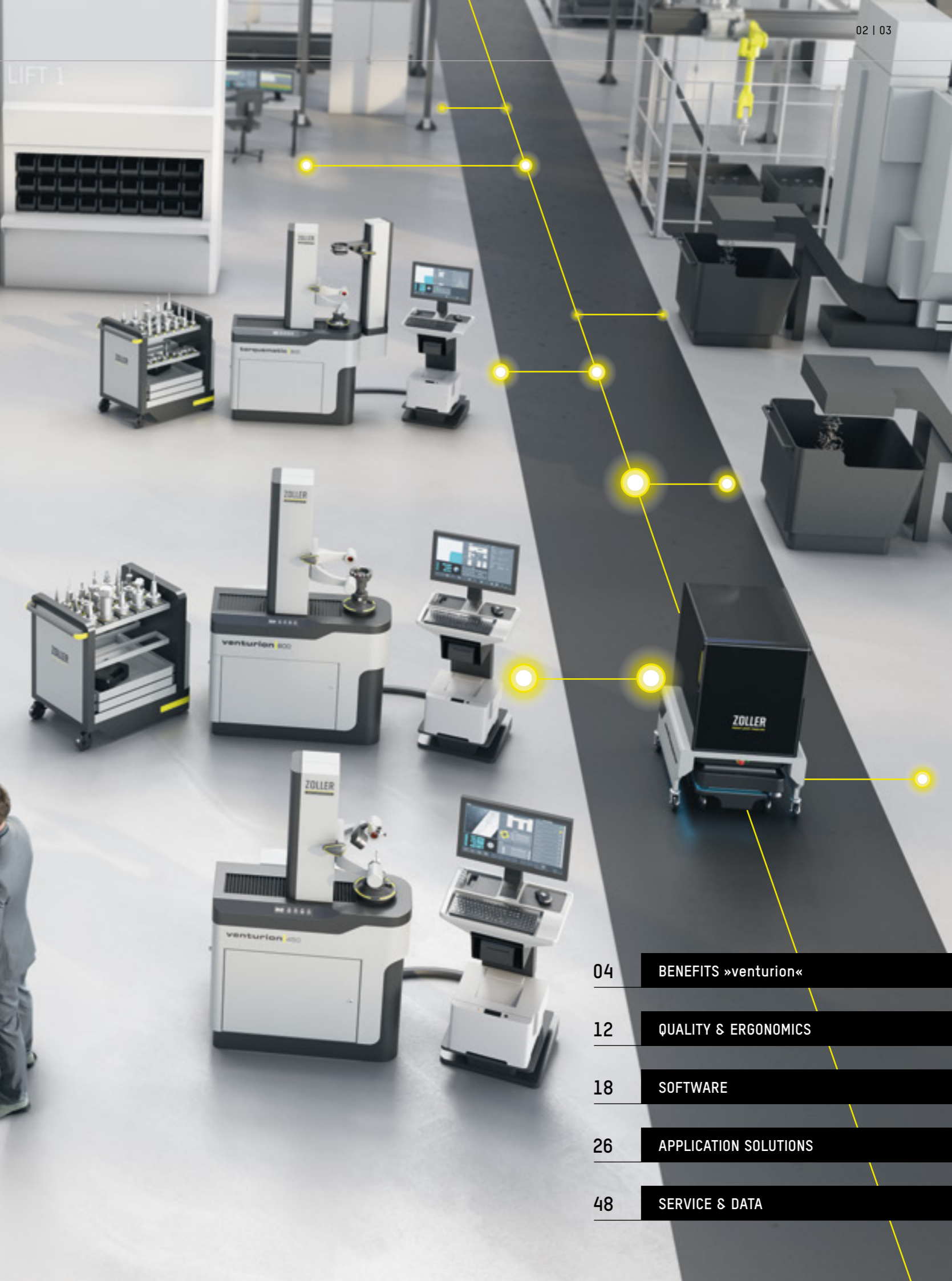

- 04 BENEFITS »venturion«
- 12 QUALITY & ERGONOMICS
- 18 SOFTWARE
- 26 APPLICATION SOLUTIONS
- 48 SERVICE & DATA

Elegant and Strong

The best teammate you can have: the premium presetting and measuring machine »venturion«. The robust body consists of a light alloy specially developed for measuring machines. Made from exclusively high quality brand-name components with exceptional craftsmanship, nothing can compare to »venturion«.

These precision machines can be used in any configuration and with any of the optional extensions – even the highest workload can be handled with ease. Its robust design makes »venturion« equally suited for a climate-controlled room or in the production hall right next to the CNC machine.



Technical Data: »venturion«

	Maximum tool length Z	Measuring range X axis	Maximum tool diameter D	Maximum snap gauge diameter D
»venturion 450«	450 / 620 / 820 mm	210 / 310 mm	420 / 620 mm	100 mm
»venturion 600«	600 / 800 / 1000 / 1200 mm	300 / 400 mm	600 / 800 mm	200 / 100 mm
»venturion 800«	600 / 800 / 1000 / 1200 / 1400 / 1600 mm	500 / 600 / 700 mm	1000 / 1200 / 1400 mm	200 / 0 mm

Maximum Process Reliability

Processes must be as precise and reliable as the measurements on which they are based. In a »venturion«, electronics, mechanical components and the ZOLLER »pilot« image processing software automatically work closely together to rule out measurement and data transfer errors. This guarantees maximum process reliability.

Automatic Zero Point Monitoring: Prevents Machine Crashes –

The software function Automatic Zero Point Monitoring in the »pilot« image processing software and the high-precision spindle »ace« work together to ensure that the zero point is automatically selected after the tool holder adapter is changed. For more machine safety.

Automatic Production Data Acquisition: Quick System Check – The software module »fingerprint« in »pilot« continuously checks at defined intervals whether all system components are functioning. The software detects errors before they occur and guarantees that your »venturion« presetting and measuring machine runs and runs – smoothly.

Statistics provide information on how often and by whom measurements are carried out on your machine. This data can be used to optimise processes, planning and machine utilisation.

Automatic Data Transfer: Error-free and Process-reliable – The best way to continue working without manual data entry is to ensure all actual tool data is correct and readily available. »venturion« can be integrated into your network and, if desired, transmits all relevant data to your CNC machines in a control-specific manner.



Measurably More Profit

With »venturion« you save time, reduce tooling costs and increase process reliability. How does it work? It is simple: With preset tools, you reduce set-up time on the machine and increase productivity. With optimally set tools you achieve longer tool life, and with defined outer contours you avoid machine crashes.

In addition, the digital transmission of the tool data guarantees secure, error-free data input. And thanks to the high quality of the machine and brand-name components, with the ZOLLER »venturion« you get a reliable partner for many years which reduces your maintenance costs to a minimum. In short: with »venturion« you simply increase the efficiency of your production.





”

CHRISTIAN HANTKE, part of the ZOLLER assembly team

For Quality I Give Everything – Every Day

Maybe you already know me. Just have a look at the seal of approval of your ZOLLER machine. Because every ZOLLER employee who assembles a machine is listed there with his picture and his name. We do this because we rely on the quality of our work. We know what quality means, how to ensure quality and what quality is all about. For example, using the best components. And about love of detail. And about experience. You can rely on all this at ZOLLER. Because it is important to us.

Highest Quality for Long-lasting Precision

ZOLLER consistently focuses on quality: Thanks to high quality brand-name components and process-reliable assembly. You can rely on a long service life of your ZOLLER machine and the highest long-term precision.



»venturion« TÜV approved

The »venturion« system is certified according to international IEC/EN 61010-1 and cNRTLus standard.

Proven and certified safety of the product.

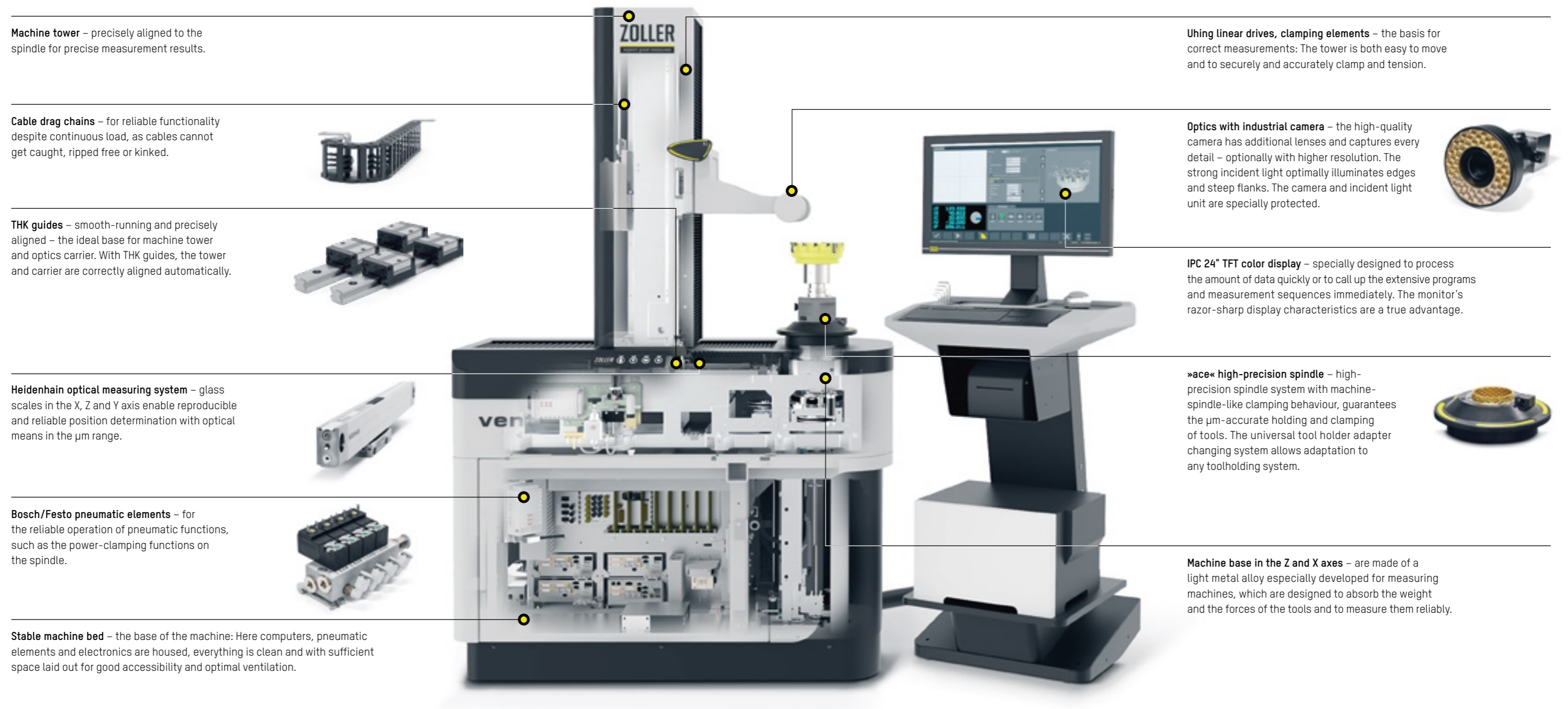

Machine tower – precisely aligned to the spindle for precise measurement results.

Cable drag chains – for reliable functionality despite continuous load, as cables cannot get caught, ripped free or kinked.

THK guides – smooth-running and precisely aligned – the ideal base for machine tower and optics carrier. With THK guides, the tower and carrier are correctly aligned automatically.

Heidenhain optical measuring system – glass scales in the X, Z and Y axis enable reproducible and reliable position determination with optical means in the μm range.

Bosch/Festo pneumatic elements – for the reliable operation of pneumatic functions, such as the power-clamping functions on the spindle.

Stable machine bed – the base of the machine: Here computers, pneumatic elements and electronics are housed, everything is clean and with sufficient space laid out for good accessibility and optimal ventilation.

Using linear drives, clamping elements – the basis for correct measurements: The tower is both easy to move and to securely and accurately clamp and tension.

Optics with industrial camera – the high-quality camera has additional lenses and captures every detail – optionally with higher resolution. The strong incident light optimally illuminates edges and steep flanks. The camera and incident light unit are specially protected.

IPC 24" TFT color display – specially designed to process the amount of data quickly or to call up the extensive programs and measurement sequences immediately. The monitor's razor-sharp display characteristics are a true advantage.

»ace« high-precision spindle – high-precision spindle system with machine-spindle-like clamping behaviour, guarantees the μm -accurate holding and clamping of tools. The universal tool holder adapter changing system allows adaptation to any toolholding system.

Machine base in the Z and X axes – are made of a light metal alloy especially developed for measuring machines, which are designed to absorb the weight and the forces of the tools and to measure them reliably.

Maximum Ergonomics for Better Working Results

At »venturion«, work facilitation is a top priority: Everything functions simply and safely. Individual adaptations and 180 degree accessibility guarantees a comfortable work environment with everything in close range.

Smooth-running machine tower – easy access to the working location – without effort.

Simple operation – the clearly structured graphical structure in the software interface guides the operator intuitively through the presetting and measuring sequence.

Many things run automatically – the operator only has to press Start. And thanks to the practical help menu and detailed operating instructions in 18 languages, no questions remain unanswered – smooth processes are guaranteed.

Practical storage board – takes tool holder adapters, and tools.

Comfortable membrane keypad – can be operated easily and safely under workshop conditions, is dust- and dirt-resistant and has a pleasant feel.

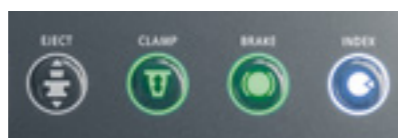

»eQ« (ergonomic & quick) one-hand control handle – the optic carrier can be moved easily in Z and X. Further functions can be integrated into the button with the solutions sign to make the operation even more easy and comfortable.



Automatic illumination monitoring – during incident light measurement, the illumination intensity adjusts automatically so that the tool is optimally illuminated. In transmitted light, the illumination intensity is constantly monitored and automatically controlled.

Practical hand wheel – for easy and safe positioning of the spindle – if the machine is to be operated manually.

Separate control unit »cockpit« – provides space for keyboard and mouse, as well as shelves for label and laser printers, scanner and tools.

The monitor can be adjusted in height and inclination, making the use of the software as comfortable as possible. This means that every operator can set up the workstation individually in just a few steps.

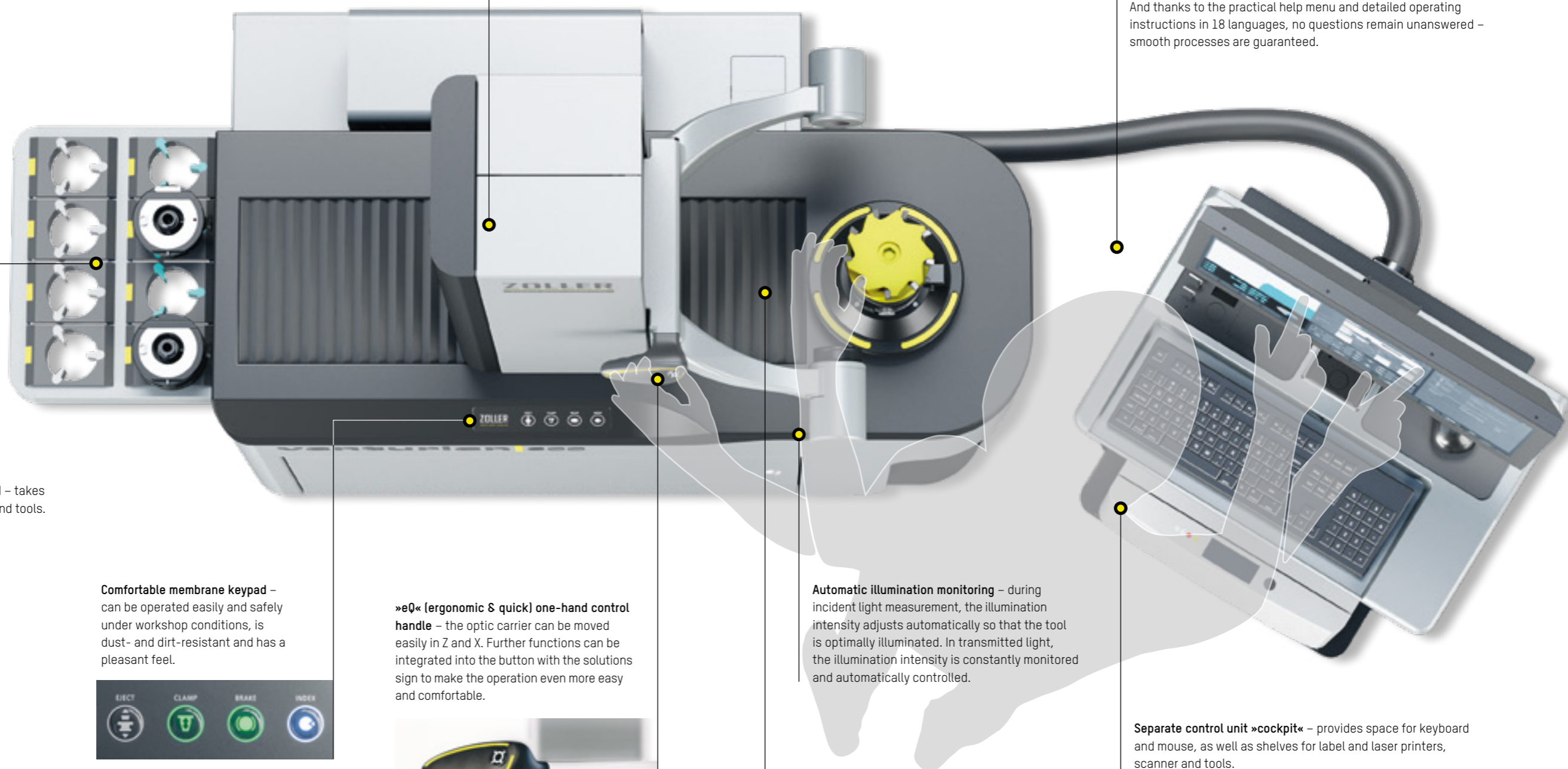

High-precision Spindle »ace«

The ball bearing cage in the spindle takes any tool holder adapter clearance-free and without conversion measures. The corresponding tool holders can be inserted into these and clamped power-operated – analogous to the machine tool.

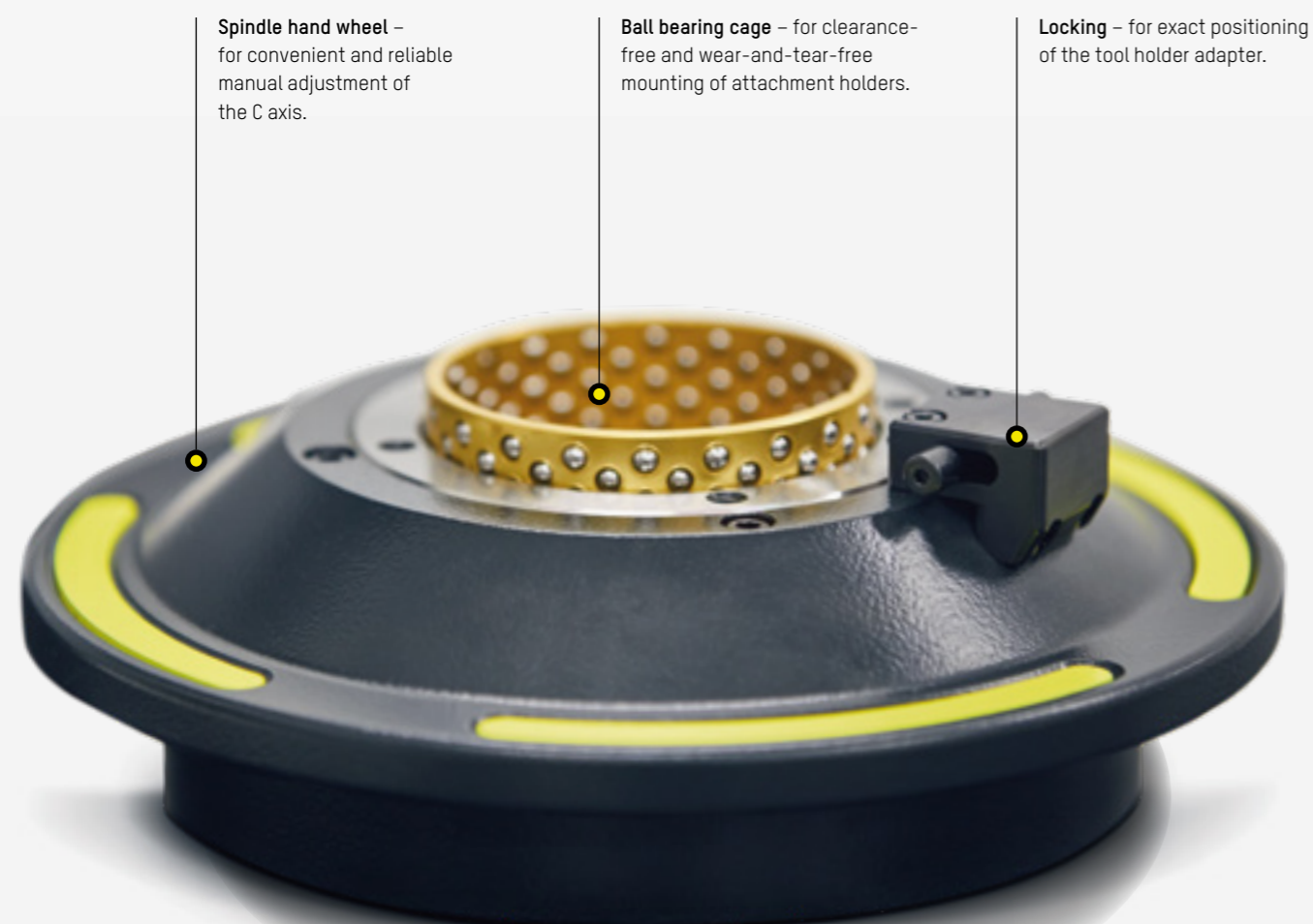

Spindle hand wheel – for convenient and reliable manual adjustment of the C axis.

Ball bearing cage – for clearance-free and wear-and-tear-free mounting of attachment holders.

Locking – for exact positioning of the tool holder adapter.

Further highlights of the ZOLLER »ace« high-precision spindle:

- **Power-activated tool clamp** – consistent independent of the individual user.
- **Spindle brake** – for pneumatic positioning of the spindle in the desired position over the entire 360°, for example to set the tool.
- **Spindle indexing** – for defined fixing of the tool position in 4 × 90°, for example, for the position indexed holding of turning tools.
- **Tool holder adapter with integrated calibration spheres** – for simple, fast and exact determination of the spindle zero point.
- **Fast tool holder adapter changeover** – in a maximum of 10 seconds.
- **High changeover accuracy** – of tool adapter holder better than 1 µm.
- **High axial and radial runout accuracy** – better than 2 µm as a result of clamped tool adapter holders.

Options: Can be extended with autofocus, rotation encoder (ROD) and length adjustment system if required. All »venturion« models are also available with SK 50 spindle. Reinforced spindles for very heavy tools are available as an option.

Always the right tool adapter holder



Steep taper SK 25 to SK 60



Polygonal shank coupling PSC 32 to PSC 100



Hollow taper shank HSK 25 to HSK 160



Kennametal KM 32 to KM 100



Cylinder shank VDI 16 to VDI 60



Hydro expansion cylinder shank D 32 mm with change bushes D 3 to D 25 mm

Eject tool

Power-clamping

Spindle brake

Spindle indexing

Membrane keypad for controlling pneumatic functions

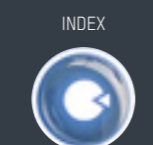
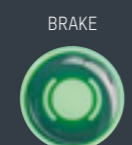
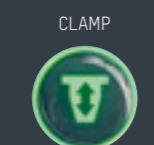

»pilot« is Always on Course for Success

»pilot« is the comprehensive software solution for all ZOLLER presetting and measuring machines. The intuitive graphical user guidance guides the user quickly and reliably to the precise measuring result. This makes »pilot« so easy to operate that even complex measuring tasks can be performed right away.

At the same time, the software is so comprehensive in its functionality that there is a solution for every requirement. It is not for nothing that »pilot« is regarded as the benchmark for tool presetting, measuring and inspecting that is unequalled anywhere in the world.

Tool designation for individual identification

Dynamic crosshair

Live image of the tool

Angle specification with selectable reference axis in the coordinate system

Setpoints with tolerance specification

Current position specification of the axes

Automatic cutting edge shape recognition Function

Tool-specific information

Text and graphically stored adapter management

Different cutting shapes for different tool contours

Function buttons with self-explanatory icons

Correct Measurement Sequences with »fored«

Unrivaled in its simplicity: The photo-realistic input dialog "fored" guides every operator safely through the parameter input of measuring programs. The required parameters are highlighted in the input mask. At the same time, the photo-realistic image highlights the corresponding point. This prevents errors when entering parameters.

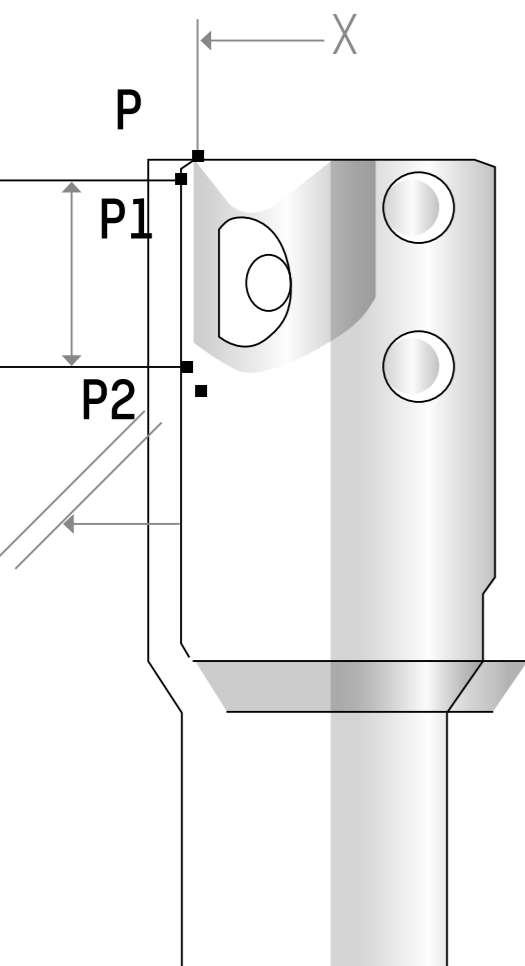

P3
P4

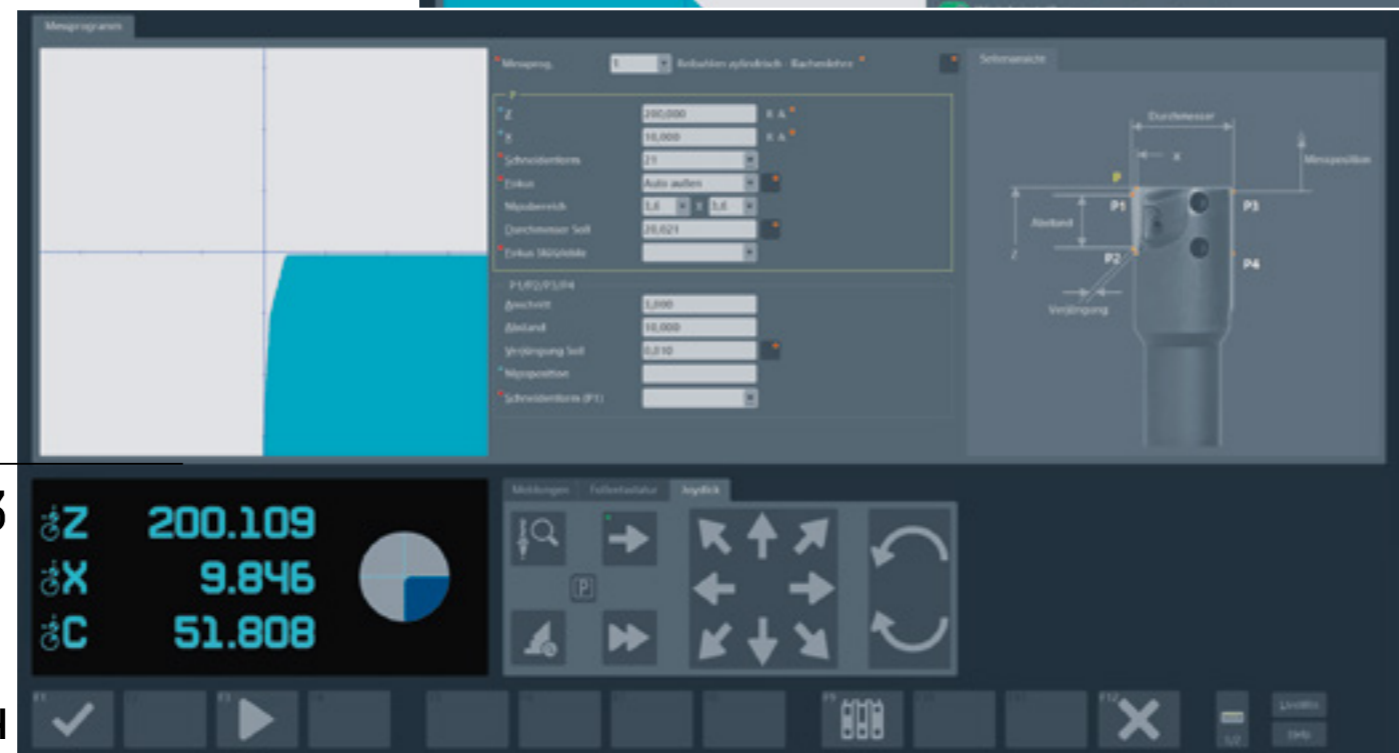

Measurement of single cutting reamers with support bar in the snap gauge principle. (measuring program 1)

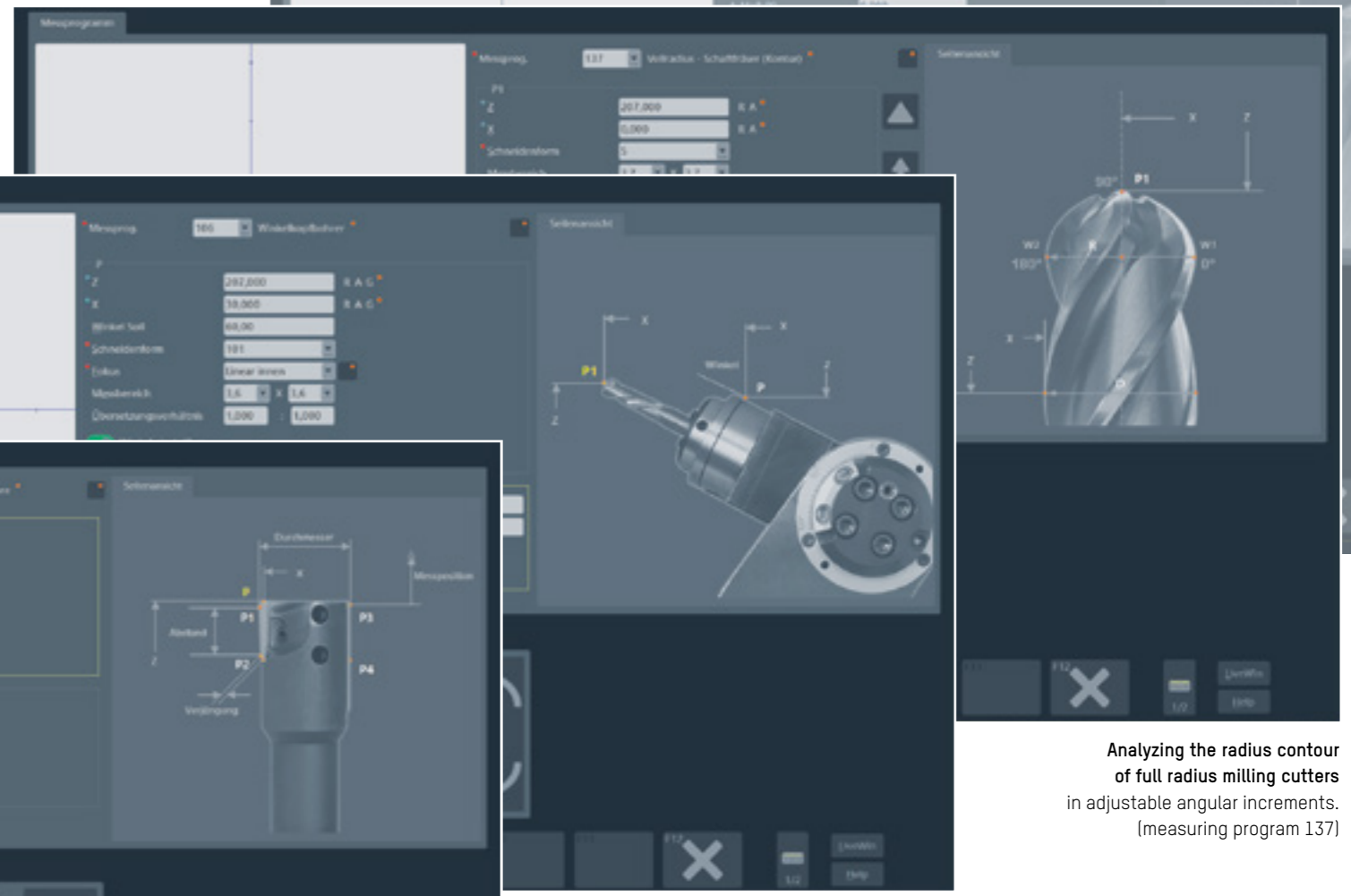

Analyzing the radius contour of full radius milling cutters in adjustable angular increments. (measuring program 137)

Adjustment and measurement of drills in angle heads. (measuring program 106)

Perfect Measurement without Specifications

The »venturion« standard is absolutely simple: You insert the tool and move the camera to the desired measuring position. A »venturion« does not need any more information. For example, it recognizes automatically the cutting edge shape, the measuring range and the steps of each tool.

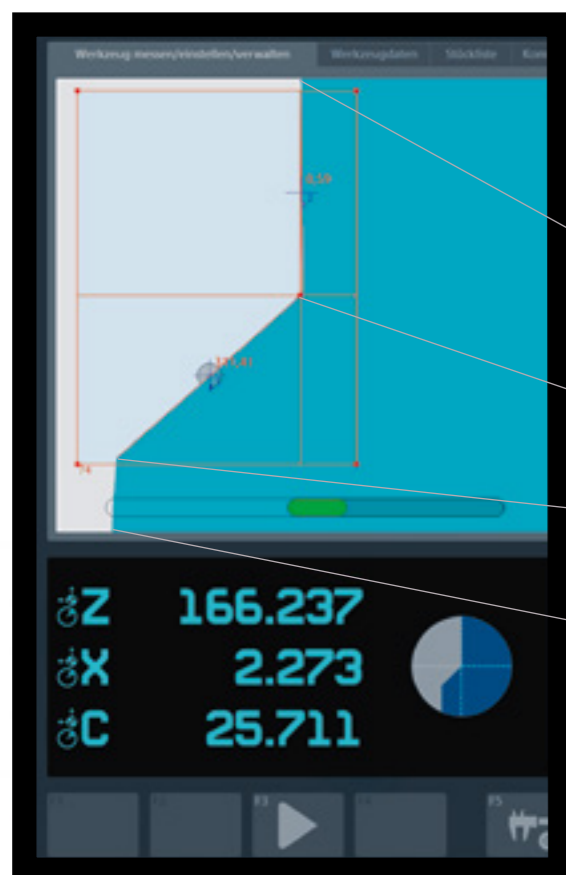

01

Insert and clamp the tool – and start »elephant« – via the main menu or the lower menu bar.

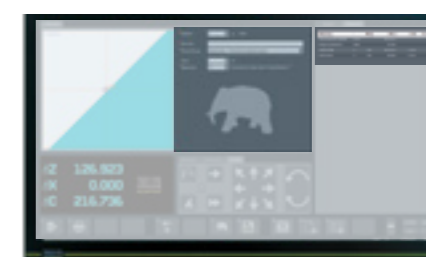

02

Select tool category – based on the graphical representation.

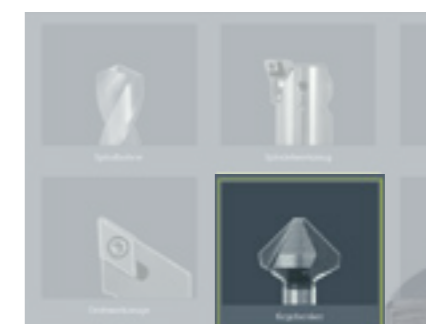

03

Select measurement task and measurement mode – based on the determining parameters. The measurement starts without any programming effort.



Measurement results – are displayed and archived on the screen. The output follows in the editable »apus« inspection report.

Werkzeug	Zählung	Messwert		
111 MFP7				
Thrombozytische Spitze	Th.S.	115,214		
Nennungswinkel	NW	44,79		
Längsmessl.	Z	115,214	0,254	
Quermessl.	X	0,000	0,009	

1, 2, 3, Finished – That's How Intuitive Measuring is with »elephant«

With the software module »elephant« every employee can really measure standard tools – without previous training. All that needs to be done is to select the tool and the measuring task – the measuring takes place fully automatically. It could not be simpler.



Manufacture Economically

Measuring at the touch of a button: A »venturion« with CNC axes and autofocus can measure any tool fully automatically – reproducibly and independently of the operator.

After inserting the tool, the operator starts the measuring process at the touch of a button. The exact measured values are available after a minimum measuring period – and your tools produce good parts in the machine from the outset. Lot size 1 is therefore also economical.

CNC control of the Z, X and C axes – for automatic movement of the axes and exact position determination.

ZOLLER
expect great measures



»venturion« TÜV approved

The »venturion« system is certified according to international IEC/EN 61010-1 and cNRTLus standard.

Proven and certified safety of the product.

Exact autofocus – the spindle automatically rotates precisely to the focus point of the camera.



Shrink in Exact Length with »redomatic«

»redomatic 600« is the high-end solution for automated measuring, presetting and shrinking. With it you can shrink tools with a precision of better than 10 µm to the exact length. With this device you increase the efficiency in the preparation of single and multi-spindle tools and protect your shrink holders. In addition, you have all the possibilities offered by a »venturion« for measuring and presetting tools.



Flue gas suction for high work safety
The flue gas suction device reliably removes flue gases from the working area.



Best operator guidance with »sls«
The shrink control system »sls« eliminates process errors as far as possible by guiding through all steps and displaying the required components.

Mounting Polygon Holders with »tribos«

With »tribos 600« you assemble and measure the length of the SCHUNK TRIBOS type polygonal shrink holders µm-accurately. The machine positions the TRIBOS clamping unit, controls the TRIBOS pressure control and the search run for aligning the SCHUNK clamping surfaces. Everything automatically. Everything precise. Everything perfectly controlled.



Fully automated with »tribos«
The SCHUNK TRIBOS clamping unit is automatically positioned to the clamping position and returned to the starting position at the end of the clamping/ unclamping process.

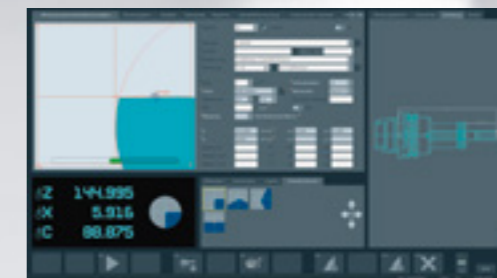

Securely supported by »pilot«
The optimum interaction between the »pilot« image processing software and the control of the TRIBOS clamping unit from Schunk ensures that the tool length can be set µm-accurately.

Presetting and Measuring with »reamCheck«

With »reamCheck« you can set complete processing tools such as reamers and precision drills fully automatically, quickly, with repeat accuracy and independent of the operator. The integrated control measurement offers you the desired safety.

The tailstock can be easily lowered with the aid of the operating handle and holds long, slim tools in exact position with a defined contact force.

Thanks to the outstanding ZOLLER technology, you can carry out all steps with ease and absolute process reliability. Whether you prefer to use a tactile measuring method for the presetting process or the proven ZOLLER image processing technology, »pilot« is your choice. One thing is for sure: It could not be better!



Measuring program selection

Extensive measuring program selection in »pilot« with photo-realistic input dialog for simple operation and reliable nominal dimension specification.



Tactile presetting of tool cutting edges

With the aid of an analogue dial gauge, tool cutting edges on reamers as well as on face cutter heads can be adjusted in »pilot« tactile μm -accurate.



Photorealistic measuring programs for reamers

Irrespective of the reamer to be measured and the desired measuring method, the user can select the appropriate measuring program from a library.

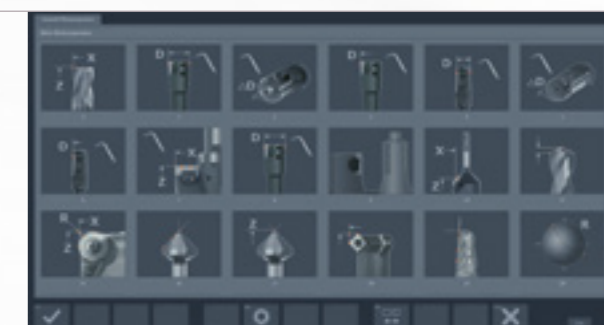

Tactile CNC controlled measurement

With the aid of a double probe, two measuring points on the tool cutting edge can be approached simultaneously and both cutting point and taper can be set.



Electronic measuring probe "duo"

For simultaneous presetting and measuring of diameters and tapers of e.g. reamers in oversize principle. The probes are magnetic and can be mounted as required.

Automatic with CNC control

Fast and CNC controlled axial run-out or radial runout measurement on cutter heads or CAP cutters.



Comprehensive Control with »smartCheck«

In addition to the geometric data of the tools, which are purely relevant for production, the quality of the cutting edge is also important. The »smartCheck« presetting, measuring, and inspection machine can visualize the surface quality of the cutting edge on the face and circumference by control in transmitted and incident light. With the help of the tool analysis software »metis« the generated images can be evaluated and analyzed.



Presetting, measuring, and inspection machine »smartCheck«

Presetting, measuring, and inspection machine »smartCheck«

With the help of the swivelling incident light camera, additional tool parameters, geometric data and cutting edge contours can be recorded both radially and axially.

The cutting edge is optimally illuminated by the LED ring light with adjustable light intensity, so that the tool contours are displayed brilliantly.

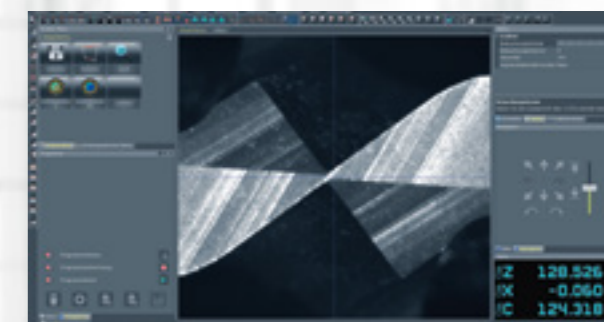

Face of the tool in the »metis« tool analysis software

Cutting edge inspection

Each presetting and measuring machine has the cutting edge inspection function. This allows a tool cutting edge to be inspected and evaluated qualitatively. The movable crosshairs, the dimmable incident light and the freely on the monitor image placeable radius make the analysis particularly easy. For complete documentation, images can be saved at any time during the cutting edge inspection.



Cutting edge inspection

Center height measuring device

For turning tools, the radial position of the tool cutting edge (centre height) is the essential parameter for exact turned part production. This center height can be determined on a vertical measuring machine with the aid of the horizontally aligned turning center measuring camera.



Center height measuring camera on optics carrier with LED ring light

Fully Automatic Clamping with »torquematic«

The »torquematic« presetting and measuring machine from ZOLLER allows tools with collet holders to be set fully automatically, without muscle power, to length, clamped to a predefined torque and measured. The automatic torquing station clamps tools without any effort. Your employees will be thrilled!



Clamping tools securely

The clamping nut is tightened in the screw station by rotation of the high-precision spindle »ace« with dual drive according to a predefined torque and the tool is clamped.



Quick change system »adaptYourHolder«

Using the »adaptYourHolder« quick-change system »torquematic« adapts to the shapes of the union nuts of your clamping systems.

Tool Assembly Made Easy with »screwmatic«

Many tool holders for cylindrical shank tools with Weldon surface or hydraulic holders have a horizontally arranged clamping screw. Using three CNC controlled linear axes, the »screwmatic« screw station can move to any horizontal screw position with μm accuracy. A torque-controlled screw axis carries out the screwdriving process precisely.

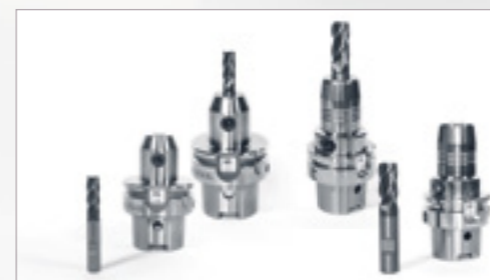

Cleverly screwed in

With horizontally arranged clamping screws, the screwing in and unscrewing is automated and the defined torque of the tool systems is set and monitored.



All fully automatic

The complete tool is inserted into the presetting and measuring machine and the screw-in position is approached automatically. The screw is tightened or loosened under torque control.

Options

Manual fine adjustment

Handwheels for additional manual fine adjustment of the Z and X axis especially for the tool inspection module.



Measuring probe

For tactile measurement of tool cutting edges.



CNC swivel device

For distortion-free measurement of inclined tools such as threading tools and hobs.



»asza« length setting system

CNC controlled linear adjusting equipment for adjusting tools to length using a limit pin. Alternatively available as »asza-rot«, with which tool length can be optionally set via the automatic rotation of the length adjusting screw (does not apply for shrink-clamping holders).

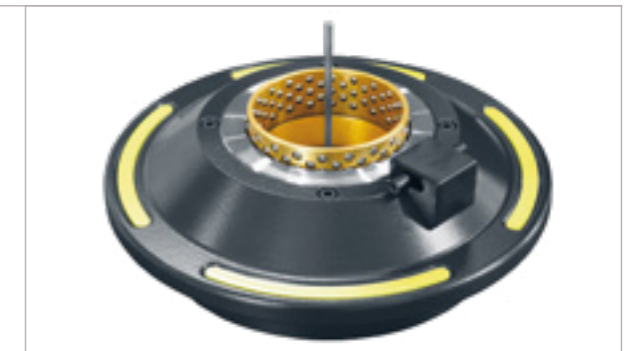

Y axis at the tower

Thanks to the additional Y axis, the optic carrier can be positioned up to ± 50 mm from the spindle center in Y-direction under CNC control. In combination with the turning center measuring camera, turning tools and multi-function tools can be measured efficiently and with high precision and adjusted to center height.

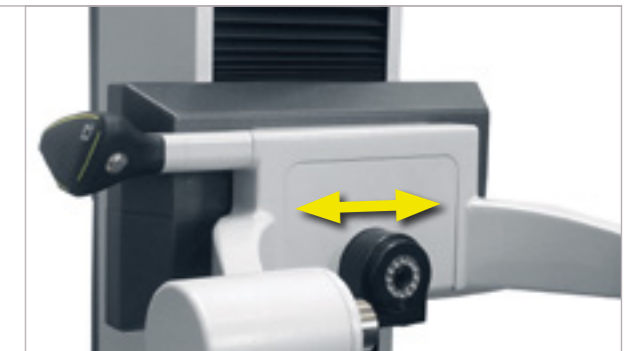

Tailstock version »phoenix 600«

The tailstock can be easily lowered and holds long, slim tools with a defined contact force in exact position. In addition to tools, components can also be measured between centers.



Identify Tools Uniquely

If machines receive the wrong tool data or are equipped with the wrong tool, this can have serious consequences. In the worst case, this can lead to an expensive machine crash. Therefore, tools must be clearly identified before use. ZOLLER has the right solution for all company sizes. Systematic tool management will increase your productivity, protect your machines from crashes and keep an eye on your inventory at all times.

Identification by Code

Barcodes, DataMatrix codes and QR-codes can be generated using the »pilot« image processing software and printed on a label. In addition, DataMatrix codes can be lasered onto the tool holders or fixed securely onto the on the tool holder by the resin-coated »idLabel«. On demand we deliver all tool holders with permanently integrated ZOLLER »idChip«. With the ZOLLER »idChip« technology you can rely on maximum product lifetime and get the perfect interface for your digital manufacturing. As soon as the tool is recognized at the CNC machine, the data can be retrieved from the database via the communication platform »zidCode« or transferred to the machine control system via the host computer system.

Scan Codes Automatically

The camera »autoIDscan« scans all codes automatically, directly on the ZOLLER presetting and measuring machine.

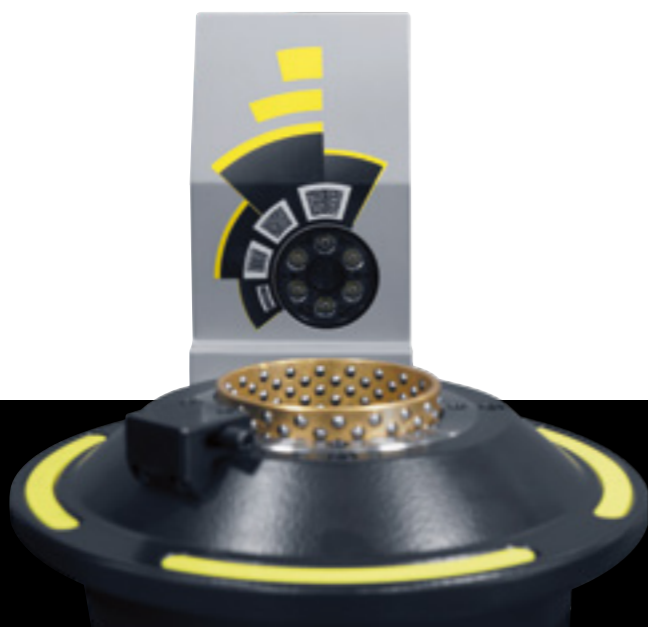
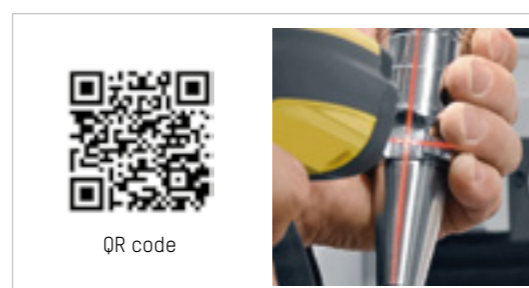
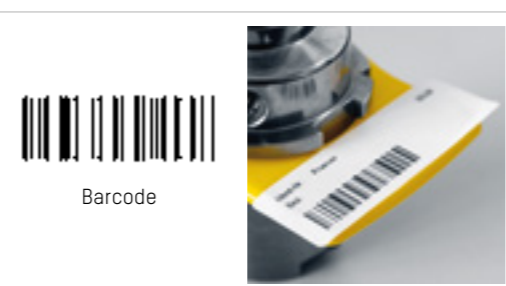

Tool Recognition with RFID

Radio-based RFID technology is ideal for absolutely safe data transfer. Each tool holder is equipped with an RFID chip to which all actual data and other control data are transmitted via radio signal from the presetting and measuring machine. At the CNC machine this data is read out again. The write and read processes can be fully automatic, manual or with a hand-held reader. With RFID you can use a fast, secure and efficient technology.

Data Transmission – Safe, Easy, Fast

Tool data can only effectively support production if it can be transferred at different points in the manufacturing process. ZOLLER offers you several options for this - depending on how large your production is, how comprehensively you want to use your tool data and how you want to organize the data transfer.

Actual Tool Data – Ready for Take-Off

Plain text on a label

The most cost-effective option is to print tool data in plain text on a label and attach the label to the tool. The data is then entered manually on the CNC machine. There are 10 layout variants available for designing the label.

Transfer data with the ZOLLER communication platform »zidCode«

With the ZOLLER communication platform »zidCode« you can play it safe. You print your tool ID number as an encrypted DataMatrix code on an »idLabel« and attach the label to the tool holder. Or you use tool holders with ZOLLER »idChip«, so you can identify your tool holders at any time clearly in your digital manufacturing process.

Postprocessing data

With the aid of postprocessors, you can prepare tool data in controller format and ensure transfer to the machine. This means that you have fulfilled all requirements for direct control of the machine.

Data transfer via RFID chip

A special identification unit on the presetting and measuring machine transmits the tool data and other control-relevant information by radio to an RFID chip. This is done either automatically, manually or via a hand-held reader.

Successful Arrival – Machine Produces

Typing on the machine

The operator reads the tool data from the label and types it in manually on the machine. To make it easy for the operator to identify the tools, additional tool images are displayed on the set up sheet.

Scan and go

The tool is identified by scanning the »idLabel« or the ZOLLER »idChip« on the machine. The associated tool data is either requested from the z.One database or transferred to the »zidCode« control. There they are processed and then read in by the machine control. Input errors are thus a thing of the past.

Transferred directly to the machine

The data prepared in controller format by postprocessor can be transferred directly to the machine via the network, USB stick or RS232 interface.

Tool sends data

At the machine, the data from the chip is automatically read in by radio. For absolutely safe data transfer.



⌘Z 115.839
⌘X 13.193



ZOLLER Solutions for Data Transfer

Label printer

For printing the measurement results or DataMatrix codes on adhesive paper or thermal labels.



Automatic RFID read/write station

For automatic writing of measurement and presetting data as well as additional information in controller format on an RFID chip and for reading out these data records.



»zidCode«

With the communication platform »zidCode« you benefit from correct and complete tool data, which can be transferred to your machines quickly, paperlessly and therefore guaranteed without typing errors.



Manual RFID read/write station

»mslz« – hand-held device

For manual reading/writing of the code carrier on the tool via a hand-held reader.



Data transmission in controller format via postprocessor

Data transfer from the presetting and measuring machine »venturion« directly to the CNC machine, quickly and easily at the touch of a button.



Manual RFID read/write station »msle«

For manual reading and writing of the RFID chip in the head bolt or on the driving groove. For free mounting on the »venturion« or separately on a workbench.



Hand-held scanner

For reading tool data from codes like the DataMatrix code on the ZOLLER »idChip« for unique identification.



Automatic camera »autoIDscan«

Special camera system used to read even large DataMatrix codes with an edge length greater than 5 mm.



»roboBox« Automation System

If you use multiple shrink-clamping tools each day, you will benefit immediately from the »roboBox«. With up to six modules, you can individually expand the »roboBox« to create a fully automatic system for fitting, measuring and cooling tools. Your advantages: high throughput, high precision, high tool availability.

»roboBox« can handle all shrink-clamping processes independently with just the combination of the three measuring, shrink-clamping, and cooling modules. Work with tools shrink-clamped to a precise length and exactly measured in fully automatic series production. Unclamp tools quickly that have reached the end of their tool life or that are defective. ZOLLER »roboBox« can be easily integrated into any production and put into operation quickly.



ZOLLER »roboBox« automation system

»roboBox« – Interfaces



In- and output

Regardless of how you infeed and remove your tools, the lock system can always be adjusted to your logistics process: whether manually, using a tool cart or via a transport system.

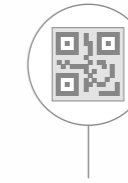

Identification

Tools can be identified optionally with a DataMatrix code or using another tool identification system via RFID Chip.

»roboBox« – Assembly processes



Heat shrinking

The induction coil lowers automatically over the tool holder and heats it. The shank tool is inserted precisely positioned and then cooled contour-independently in a cooling module, which has capacity to hold up to eight complete tools. This accelerates the cycle time.



Screw fitting collet holders

Matching adapters can be used to automatically clamp the clamping nuts to a defined torque in collet holders. Switching between clamping adapters is also automatic. Adapters are available for nuts in cylindrical, hexagonal, and fluted versions.

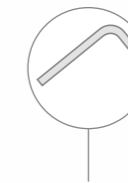

Screw fitting clamping screws

Screws are clamped and released automatically for horizontally arranged clamping screws, like those used on cylinder shank tools with Weldon areas or hydroexpansion holders. At the same time, the defined torque for the tooling systems is set and monitored.

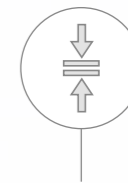

powRgrip® presses

The tool with matching collet holder and REGO-FIX powRgrip® collet holder is infeed and pressed automatically.

»roboBox« – Measurement processes

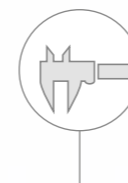

Tool geometries

After the automatic assembly process, tool geometries such as diameter, length, cutting edge radius, cutting angle and concentricity and axial run-out can be measured in automatic measurement sequences. In addition to automatic mode, manual measurements can also be carried out in the module, during which automatic operation in the »roboBox« is not interrupted.



Balancing quality

The balancing module is insulated with the highly precise measurement unit and integrated into the »roboBox« so as to neutralize vibrations. After the measurement process, the balancing quality can be transferred to the CNC machine control as a measuring parameter.

Impressively Versatile

If you decide on a »venturion« from ZOLLER, all possibilities are open to you. You will find a cosmos of first-class solutions. We will be happy to advise you on the perfect configuration of your »venturion«.

- Base model
- ⊙ optional
- not possible

Technical data	Axes					Operating software			Software functions			Data management							
	CNC control	Manual axes positioning	Manual fine adjustment	Third axis with rotation encoder	Additional Y axis at the tower	»pilot 1« on 24" monitor	»pilot 2 mT«	»pilot 4,0«	17" TFT colour display »satellit« as second monitor	Autofocus	Automatic tool holder adapter recognition and zero point monitoring	Tool tension monitoring	Data transfer via postprocessor	Tool identification »msiz«	Read/write station »msle«	Automatic tool identification	»zidCode« with labels	DataMatrix identification automatic camera	DataMatrix identification hand-held reader
»venturion 450«	●	●	⊙	●	⊙	⊙	⊙	●	⊙	●	⊙	●	⊙	⊙	⊙	⊙	⊙	⊙	⊙
»venturion 600«	●	●	⊙	●	-	⊙	⊙	●	⊙	●	⊙	●	⊙	⊙	⊙	⊙	⊙	⊙	⊙
»venturion 800«	●	●	⊙	●	-	⊙	⊙	●	⊙	●	⊙	●	⊙	⊙	⊙	⊙	⊙	⊙	⊙
»redomatic«	●	●	-	●	-	-	-	●	●	●	⊙	●	⊙	⊙	⊙	⊙	⊙	⊙	⊙
»tribos«	●	●	-	●	-	-	-	●	●	●	⊙	●	⊙	⊙	⊙	⊙	⊙	⊙	⊙
»reamCheck«	●	●	-	●	-	-	-	●	●	●	⊙	●	⊙	⊙	⊙	⊙	⊙	⊙	⊙
»smartCheck«	●	●	⊙	●	-	-	-	●	⊙	●	⊙	●	⊙	⊙	⊙	⊙	⊙	⊙	⊙
»torquematic«	●	●	-	●	-	-	-	●	⊙	●	⊙	●	⊙	⊙	⊙	⊙	⊙	⊙	⊙
»screwmatic«	●	●	⊙	●	-	-	-	●	⊙	●	⊙	●	⊙	⊙	⊙	⊙	⊙	⊙	⊙
»roboBox«	●	-	-	●	-	-	-	●	-	●	-	●	⊙	⊙	-	-	⊙	⊙	⊙

Spindle	Measurement methods, application solutions															Accessories					
	High-precision spindle »ace«	High-precision spindle SK 50/ vacuum clamping	Universal high-precision spindle, quick-change device for tool holder adapter and tension elements	Front clamping spindle	Spindle brake 60 Nm	Cutting edge inspection	Measurement in snap gauge principle	Center height measuring device	Swivable tool inspection	Tailstock	Measuring probe	CNC swivel device	Automatic length adjustment »asza«	Table reinforcement for tools up to 60 kg	Table reinforcement for tools up to 250 kg	Table reinforcement for tools up to 350 kg	Adapter storage board and utensil shelf	Tool cart	USB camera	List printer	Thermal label printer
●	⊙	⊙	-	⊙	●	●	⊙	-	-	⊙	-	⊙	⊙	-	-	⊙	⊙	⊙	⊙	⊙	⊙
●	⊙	⊙	-	⊙	●	●	⊙	-	⊙	⊙	⊙	⊙	⊙	⊙	-	⊙	⊙	⊙	⊙	⊙	⊙
●	⊙	⊙	⊙	⊙	●	●	⊙	-	⊙	⊙	⊙	⊙	⊙	⊙	⊙	⊙	⊙	⊙	⊙	⊙	⊙
●	-	⊙	-	⊙	●	●	⊙	-	-	⊙	⊙	●	⊙	⊙	-	⊙	⊙	⊙	⊙	⊙	⊙
●	-	⊙	-	⊙	●	●	⊙	-	-	⊙	●	⊙	⊙	⊙	⊙	⊙	⊙	⊙	⊙	⊙	⊙
●	⊙	⊙	⊙	⊙	●	●	-	-	⊙	●	⊙	⊙	⊙	⊙	⊙	⊙	⊙	⊙	⊙	⊙	⊙
●	-	-	-	●	●	●	⊙	-	-	⊙	⊙	●	●	⊙	-	⊙	⊙	⊙	⊙	⊙	⊙
●	-	-	-	⊙	●	●	⊙	-	-	⊙	-	⊙	⊙	-	-	⊙	⊙	⊙	⊙	⊙	⊙
●	-	⊙	-	⊙	●	●	⊙	-	-	⊙	-	⊙	-	-	-	-	⊙	⊙	⊙	⊙	⊙

We Stand for ZOLLER Solutions

Your goal is maximum efficiency for your production. Our goal is to support you with well-designed system solutions. To help achieve this goal, we also offer comprehensive service. Whether through personal consultation on site or by developing perfectly tailored solutions for individual requirements – if you choose ZOLLER, you will not only receive excellent products, but also unique production know-how on your side. And of course, competent contact partners to answer questions at any time – over the entire life cycle of the ZOLLER products.

ZOLLER Solutions – With us, you receive more than just outstanding products. You get individual system solutions connected with your tools. We combine hardware, software and services for you. Everything from a single source. Everything for your success. We call it: ZOLLER Solutions.

ALEXANDER ZOLLER, CHRISTOPH ZOLLER
Management



Comfort for Everyone – the Integrated Control Unit

The monitor on the integrated operating unit can be individually adapted to the needs of the various operators to ensure that work is carried out in a health-friendly and comfortable manner: Height, swivel angle and tilt angle are flexibly adjustable.

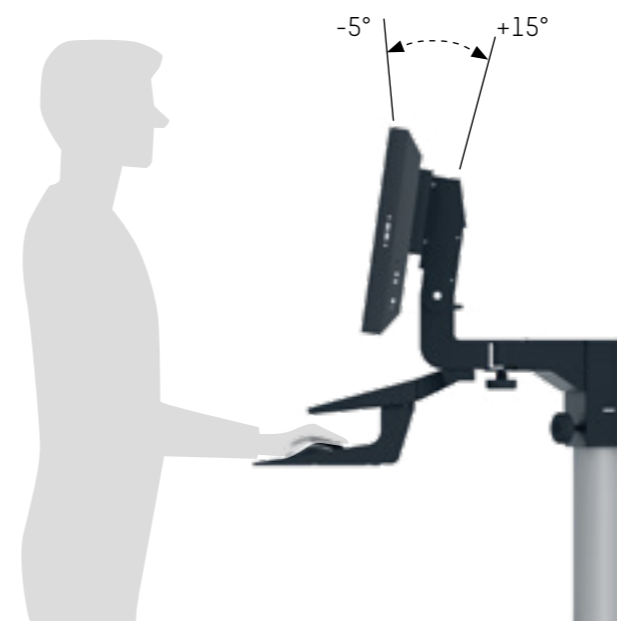
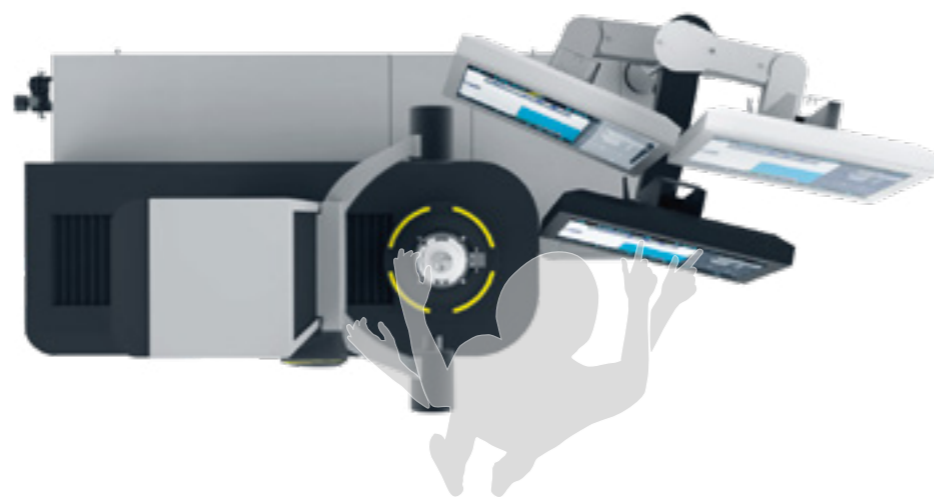

Installation Dimensions

Installation dimensions »venturion 450« with »cockpit«			
Z (mm)	Xa (mm)	Xb (mm)	H1 (mm)
450	210	310	~ 1750
620	210	310	~ 1950
820	210	310	~ 2150

Installation dimensions »venturion 600« with »cockpit«			
Z (mm)	Xa (mm)	Xb (mm)	H1 (mm)
600	300	400	~ 1936
800	300	400	~ 2136
1000	300	400	~ 2336
1200	300	400	~ 2536

Installation dimensions »venturion 800« with »cockpit«				
Z (mm)	Xa (mm)	Xb (mm)	Xc (mm)	H1 (mm)
600	500	600	700	~ 1936
800	500	600	700	~ 2136
1000	500	600	700	~ 2336
1200	500	600	700	~ 2536
1400/1600	500	600	700	~ 2936

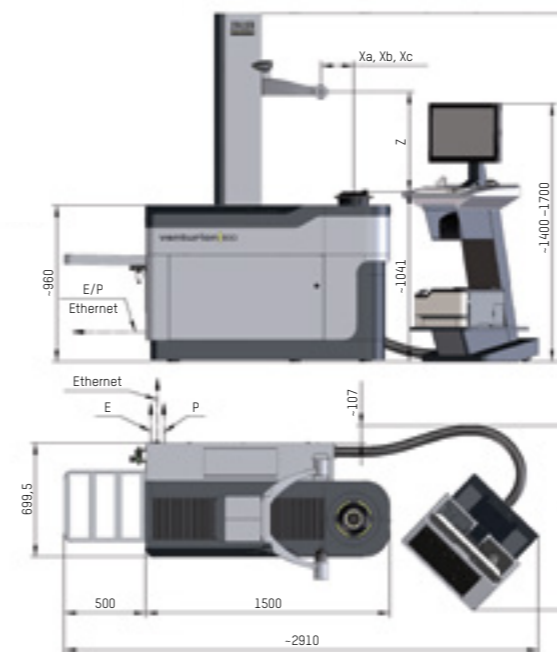
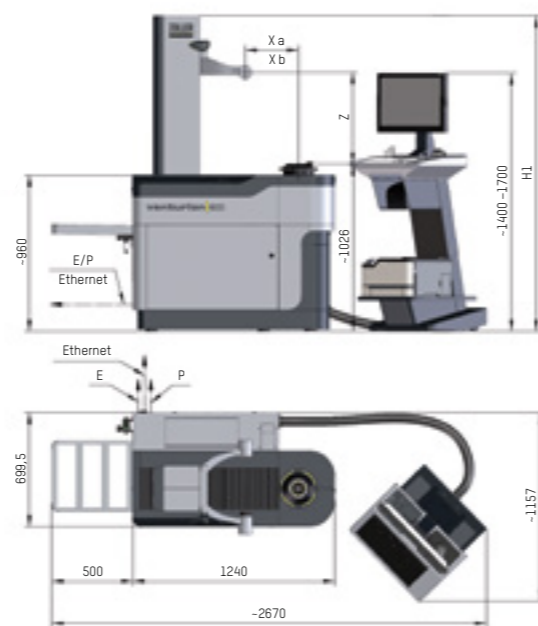
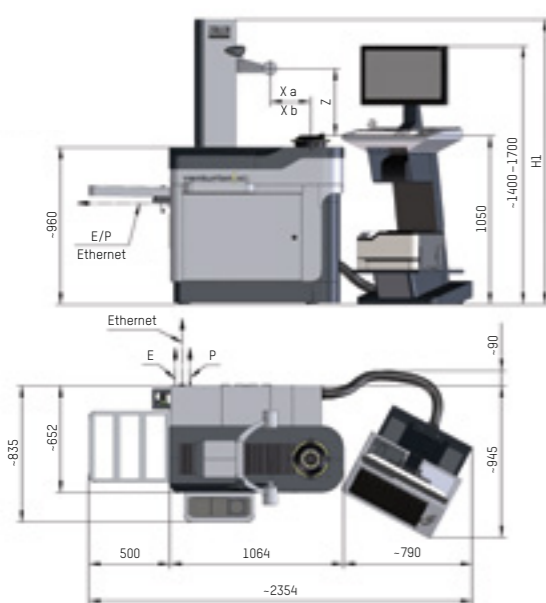

Note: P Compressed-air supply E Electricity supply



In Germany at Home – Around the World for You

ZOLLER quality is “made in Germany” – and there for you, anywhere in the world.

Our company has its own locations and branches at 85 sites in 62 countries, guaranteeing we are close to customers and can provide first-class, personal customer service in local markets.

- Parent company
- Headquarters
- Branch office
- Representative

GERMANY

HEADQUARTERS

E. ZOLLER GmbH & Co. KG
Einstell- und Messgeräte
Gottlieb-Daimler-Straße 19
D-74385 Pleidelsheim
Tel: +49 7144 8970-0
Fax: +49 7144 8970-70191
post@zoller.info | www.zoller.info

ZOLLER NORTH

E. ZOLLER GmbH & Co. KG
Service- und Vertriebszentrum
D-30179 Hannover

ZOLLER EAST

E. ZOLLER GmbH & Co. KG
Service- und Vertriebszentrum
D-04158 Leipzig

ZOLLER WEST

E. ZOLLER GmbH & Co. KG
Service- und Vertriebszentrum
D-40764 Langenfeld

EUROPE

AUSTRIA

ZOLLER Austria GmbH
A-4910 Ried im Innkreis
office@zoller-a.at | www.zoller-a.at

SWITZERLAND

ZOLLER Schweiz GmbH
CH-9016 St. Gallen
info@zoller-ch.com | www.zoller-ch.com

FRANCE

ZOLLER France
F-67380 Lingolsheim
info@zoller.fr | www.zoller.fr

SPAIN + PORTUGAL

ZOLLER Ibérica S.L.
E-08005 Barcelona
correo@zoller.info | www.zoller.info

TURKEY

ZOLLER Ölçüm Teknolojileri San.ve Tic. Ltd. Sti.
TR-16120 Nilüfer / Bursa
info@zoller-tr.com | www.zoller-tr.com

RUSSIA

LLC ZOLLER Russia
RU-111123 Moscow, Russia
info@zoller-ru.com | www.zoller-ru.com

ISRAEL

ZOLLER Israel GmbH
Ramat Yishay 3009500
info@zoller-il.com | www.zoller.info

POLAND

ZOLLER Polska Sp. z o.o.
63-100 Śrem
biuro@zoller-a.at | www.zoller.net.pl

CZECH REPUBLIC + SLOVAKIA

ZOLLER Czech s.r.o.
602 02 Brno
info@zoller.cz | www.zoller.cz

AMERICA

USA

ZOLLER Inc.
North American Headquarters
USA-48108 Ann Arbor, MI
sales@zoller-usa.com | www.zoller-usa.com

ZOLLER Inc. Pacific

USA-90503 Torrance, CA
sales@zoller-usa.com | www.zoller-usa.com

CANADA

ZOLLER Canada Inc.
CAN-LSN 864 Mississauga, ON
sales@zoller-canada.com | www.zoller-canada.com

MEXICO

ZOLLER Tecnologías S de R.L. de C.V.
MEX-C.P. 76030 San Angel Querétaro
sales@zoller-mexico.com | www.zoller-mexico.com

BRAZIL

ZOLLER do Brasil
BRA-CEP 13284-198 Nova Vinhedo,
Vinhedo - São Paulo
comercial@zoller-br.com | www.zoller-br.com

ASIA

INDIA

ZOLLER India Private Ltd.
IN-Pune 411019 Maharashtra, India
info@zoller-in.com | www.zoller-in.com

CHINA

ZOLLER Shanghai, Ltd.
Asia Pacific Regional Headquarter
RC-201108 Shanghai
info@zoller-cn.com | www.zoller-cn.com

ZOLLER Asia Pacific, Ltd.

RC-Kowloon, Hongkong
info@zoller-cn.com | www.zoller-cn.com

JAPAN

ZOLLER Japan K. K.
JP-564-0037 Osaka, Japan
info@zoller-jp.com | www.zoller-jp.com

THAILAND

ZOLLER (Thailand) Co. Ltd.
Amphur Muang Chonburi, TH-20000 Thailand
info@zoller-in.com | www.zoller-th.com

INDONESIA

ZOLLER Singapore Pte. Ltd
Indonesia Representative Office
Tambun-17510, Bekasi, Jawa Barat
info@zoller-in.com | www.zoller-in.com

SINGAPORE

ZOLLER Singapore Pte. Ltd
SG-199589 Singapore
info@zoller-in.com | www.zoller.info

MALAYSIA

ZOLLER MALAYSIA SDN. BHD.
Malaysia Representative Office
MY-Petaling Jaya | Selangor Darul Ehsan, Malaysia
lau@zoller-my.com | www.zoller-in.com

VIETNAM

ZOLLER Vietnam
VNM-Ho Chi Minh City, Vietnam
info@zoller-in.com | www.zoller-in.com

KOREA

ZOLLER Korea Co., Ltd.
KOR-15119 - Siheung-Si, Gyeonggi-Do, Südkorea
info@zoller-kr.com | www.zoller-kr.com

REPRESENTATIVES

Argentina, Australia, Belarus, Belgium, Bolivia, Chile, Colombia, Costa Rica, Croatia, Denmark, Estonia, Finland, Great Britain, Hungary, Iran, Ireland, Italy, Latvia, Lithuania, Luxembourg, New Zealand, Norway, Pakistan, Peru, Romania, Saudi Arabia, South Africa, Southern Tyrol, Sweden, Taiwan, The Netherlands, United Arab Emirates, Venezuela.



Your Customer Portal
www.myzoller.com

simple. direct. online.

ZOLLER Solutions

More speed, higher quality, safe processes – with ZOLLER, you increase the efficiency of your production. ZOLLER offers you outstandingly precise devices for adjusting, measuring and testing cutting tools, software, interfaces, cloud services and solutions for the automation of tool processes. You can combine all of this to create your individual system solution – on your way to the smart factory.

Presetting & Measuring

Tool Management

Inspection & Measuring

Automation

Everything from a Single Source.
Everything for your Success.
Everything with ZOLLER Solutions.

ZOLLER
expect great measures

Headquarters in Pleidelsheim

E. ZOLLER GmbH & Co. KG

Tool presetter and measuring machines

Gottlieb-Daimler-Straße 19 | D-74385 Pleidelsheim

Phone: +49 7144 8970-0 | Fax: +49 7144 8970-70191

post@zoller.info | www.zoller.info