

ZOLLER
AUTOMATION SOLUTIONS

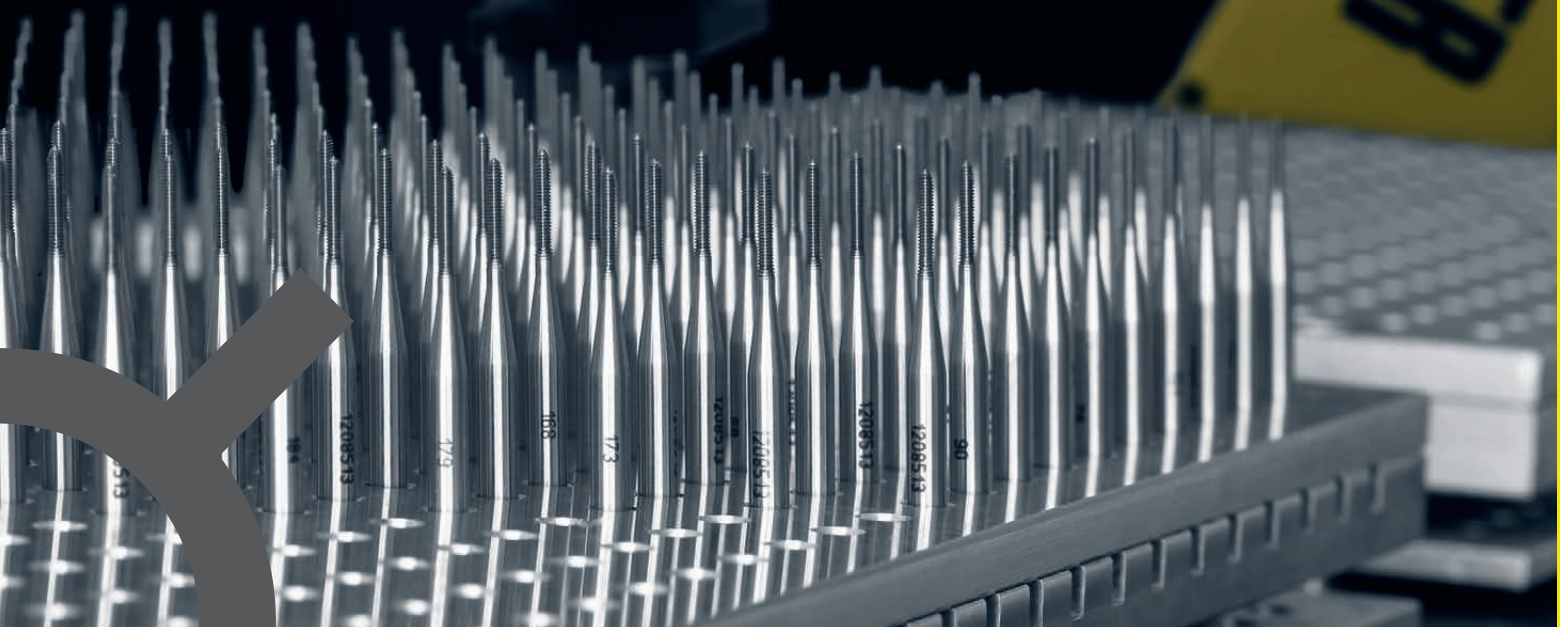

The Automation Solution for High Tool Throughput

roboSet 2

ZOLLER
expect great measures®

Working for You Non-stop: ZOLLER »roboSet 2«

Ideal for tool manufacturers with very high tool throughput who need 100% monitoring and logging: »roboSet 2«, the new ZOLLER automation solution for tool measuring, is especially fast, yet extremely compact. When networked directly with your ZOLLER universal measuring machine, »roboSet 2« can load tools around the clock, 7 days a week, completely autonomously. Thanks to a multi-pallet system and double gripper, it can process and document large numbers of tools fully automatically. The machine also guarantees maximum process security and measurement accuracy through automatic path correction during feeding, and a loading system which is mechanically decoupled from the measuring machine.



Benefits

- 100% tool control and 100% certifiable quality
- Absolute measurement precision and process security
- Autonomous measurement, 24/7

It Couldn't Be Simpler!

All you have to do is define the tool by using the pallet management in »pilot 3.0«, then start automatic operations. »roboSet 2« handles the rest for you, automatically: from loading, measuring, and removing tools, to sorting out faulty tools, archiving measured values,

and issuing measured values on logs. Even fully-automatic cleaning and labeling of tools is an option with »roboClean« and »roboMark«. During the day you use the measuring machine also self-sufficient.



Only with »roboSet 2«: 8 pallets on 2 levels

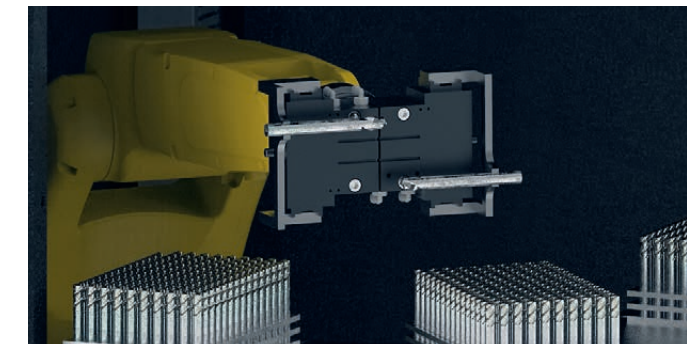

Double gripper for extra fast tool throughput



Automatic tool labeling: »roboMark«

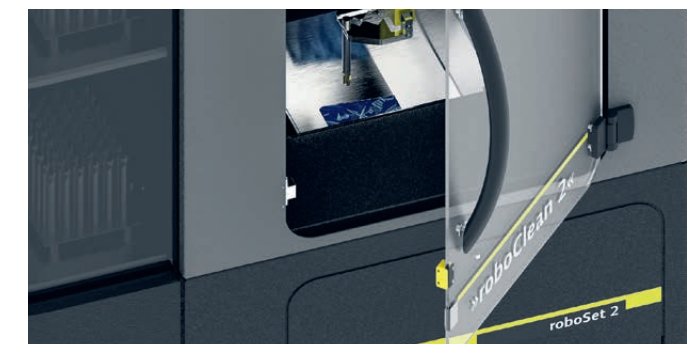

Fully-automatic ultrasonic cleaning: »roboClean«

Double gripper system for even faster tool throughput
Easy operation with multi-pallet system
Compact, space-saving design

More
than 24/7



- ___ Autonomous measuring machine operation
- ___ Maximum precision
- ___ Intuitive software



- ___ 100% documentation
- ___ Automatic cleaning and labeling
- ___ Fully automated and unmanned



Team Player

»roboSet 2« is available in combination with »titan«, »threadCheck«, and »genius« closed ZOLLER universal measuring machines. The automation solution »roboSet« is optimal for open ZOLLER measuring devices.

»roboSet 2« Requirements

- CNC controlled, closed ZOLLER universal measuring machine with automatic power clamping and »pilot 3.0« measuring machine software version 1.11.0 and later
- Tools with cylindrical shafts from \varnothing 3 to 20 mm (tool weights up to a max. of 2.0 kg)
- Minimum shaft lengths (in mm): \varnothing 3–5/30; \varnothing 6–8/48
 \varnothing 10/54; \varnothing 12–14/62; \varnothing 16–18/65; \varnothing 20/67
- Maximum tool length: 230 mm

»roboSet « Requirements

- CNC controlled ZOLLER universal measuring machine with automatic power clamping and »pilot 3.0« measuring machine software version 1.11.0 and later
- Tools with cylindrical shafts from \varnothing 4 to 32 mm (tool weight above 2.0 kg only in combination with larger robots, or with gripper exchange system upon request)
- Minimum shaft lengths (in mm): \varnothing 3–5/30; \varnothing 6–8/48;
 \varnothing 10/54; \varnothing 12–14/62; \varnothing 16–18/65; \varnothing 20/67; \varnothing 25–32/78

Technical Data	Range	Positioning Precision	Maximum Load Capacity	Working Surface Area	Number of Pallets
»roboSet 2«	920 mm	$\pm 0,03$ mm	7 kg without gripper	1050 x 350 mm	8 pieces
»roboSet«	900 mm	$\pm 0,03$ mm	5 kg without gripper	1050 x 350 mm	3 pieces

We reserve the right to make technical changes. The depicted machines may include options, accessories, and control variants.

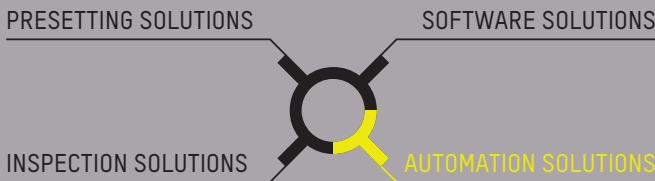

www.zoller.info

E. Zoller GmbH & Co. KG | Tool Presetting and Measuring Machines
 Gottlieb-Daimler-Strasse 19 | D-74385 Pleidelsheim
 Tel: +49 7144 8970-0 | Fax: +49 7144 8060-807
 post@zoller.info

ZOLLER
 expect great measures®