

Press Release 1/09

New Measuring Program by ZOLLER for shrink-fitting drills to a nominal length WITHOUT presetting adapter – fast, simple and micro-precise

Get »swomp« – and you will be swamped with orders!

Shrinking WithOut »MasterPiece«

ZOLLER »redomatic« is the perfect solution for shrink-fitting to a nominal length and for measuring and presetting tools of all kinds on a single machine. This presetter and measuring machine by world leader ZOLLER features an integrated shrink-fit technology for simultaneous presetting of shrink-fit tools to length and will convince you by its high precision, ergonomic design and process reliability.

Apart from working at micro-precision level when shrink-fitting to length with a ZOLLER »masterPiece«, you may experience situations when you need a faster, yet reliable method for simply changing tools or shrink-fitting similar tools of the same type in series. This requirement prompted ZOLLER to extend the shrink-fitting options of its software »pilot 3.0« with this ground-breaking feature: By using »swomp« you may now change worn tools and – at the same time – shrink-fit new tools to their nominal length. Whether you have new or re-ground tools: While the shrink-fit chuck is still open, »pilot 3.0« will adjust the actual length so fast, that the longitudinal difference between old and new tool has no part. The nominal value is set precisely, fast and reliably.

E. Zoller GmbH & Co. KG
Einstell- und Messgeräte
D-74385 Pleidelsheim

Press photo see page 2

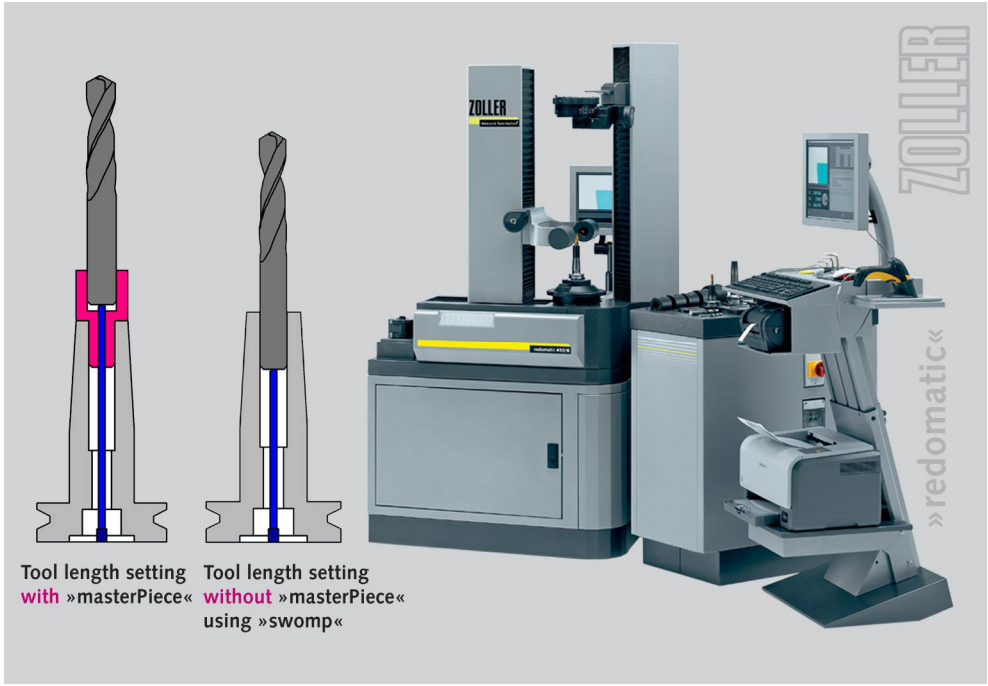

Tool length setting with »masterPiece« Tool length setting without »masterPiece« using »swomp«